

PARTS DIAGRAM 468301724,468302724

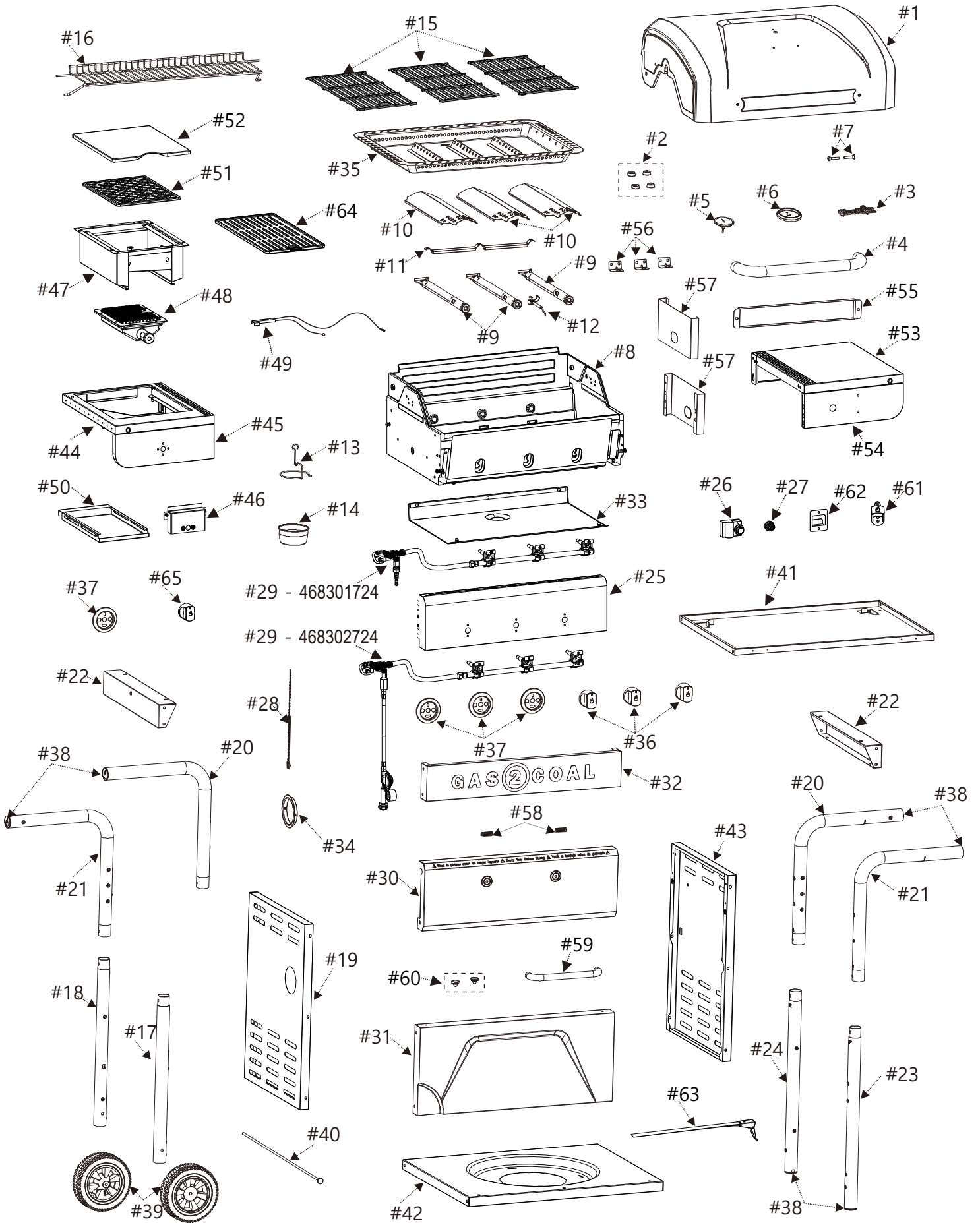





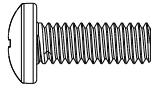
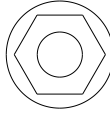
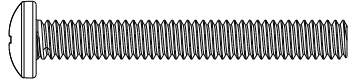
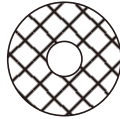
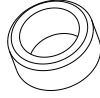

REPLACEMENT PARTS LIST

Key	Qty.	Description
1	1	TOP LID
2	4	LID BUMPER
3	1	LOGO PLATE
4	1	HANDLE
5	1	TEMPERATURE GAUGE
6	1	BEZEL, TEMPERATURE GAUGE
7	1	HARDWARE F/ TOP LID
8	1	FIREBOX
9	3	BURNER
10	3	HEAT TENT
11	2	FLAME CARRYOVER TUBE
12	1	ELECTRODE
13	1	GREASE CUP CLIP
14	1	GREASE CUP
15	3	COOKING GRATE
16	1	SWINGAWAY RACK
17	1	LEG, LEFT LOWER FRONT
18	1	LEG, LEFT LOWER REAR
19	1	LEFT SIDE PANEL, F/ CART
20	2	UPPER CART FRAME A
21	2	UPPER CART FRAME B
22	2	UPPER CART BRACE
23	1	LEG, RIGHT LOWER FRONT
24	1	LEG, RIGHT LOWER REAR
25	1	CONTROL PANEL
26	1	ELECTRONIC IGNITION MODULE
27	1	BUTTON, F/ EI MODULE
28	1	MATCH HOLDER
29	1	VALVE ASSEMBLY
30	1	FRONT PANEL, DOOR, NO HANDLE
31	1	FRONT PANEL, LOWER
32	1	FRONT PANEL, UPPER
33	1	HEAT SHIELD, TANK
34	1	GROMMET, F/ REGULATOR HOLE
35	1	CHARCOAL TRAY
36	3	CONTROL KNOB
37	4	BEZEL, F/ CONTROL KNOB
38	6	END CAP, F/ LEG
39	2	WHEEL
40	1	AXLE

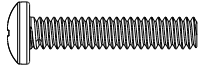
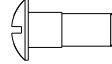
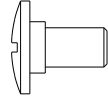
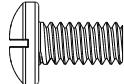

Key	Qty.	Description
41	1	STORAGE TRAY
42	1	BOTTOM SHELF
43	1	RIGHT SIDE PANEL, F/ CART
44	1	SEAR SIDEBURNER SHELF
45	1	FASCIA, F/ SEAR SIDEBURNER SHELF
46	1	SEAR SIDEBURNER VALVE BRACKET
47	1	FIREBOX, F/ SEAR SIDEBURNER
48	1	SEAR SIDEBURNER
49	1	ELECTRODE, F/ SEAR SIDEBURNER
50	1	GREASE TRAY, F/ SEAR SIDEBURNER
51	1	COOKING GRATE, SEAR SIDEBURNER
52	1	LID, F/ SEAR SIDEBURNER
53	1	RIGHT SHELF
54	1	FASCIA, F/ RIGHT SHELF
55	1	HEAT SHIELD, F/ HANDLE
56	3	BURNER BRACE
57	2	HEAT SHIELD, F/ FIREBOX
58	1	MAGNET, F/ DOOR
59	1	HANDLE, F/ DOOR
60	2	BUMPER, F/ DOOR
61	1	BOTTLE OPENER
62	1	GRATE TOOL HOLDER
63	1	TANK STRAP
64	1	GRIDDLE
65	1	SEAR BURNER CONTROL KNOB
NOT Shown		
...	1	HARDWARE PACK
...	1	PRODUCT GUIDE, EUROPE
...	1	GRATE TOOL

HARDWARE LIST

Key	Description	Picture	Qty
A	1/4-20x3/4" Machine Screw		48
B	1/4-20 Flange Nut		7
C	1/4-20x2" Machine Screw		4
D	7x15 Fiber Washer		4
E	Bushing		1
F	Hitch Pin Clip		1
G	#8-32x3/8" Machine Screw		2
H	ST4.2X6Tapping Screw Assy		2
J	#10-24x1" Machine Screw		1
K	Shoulder Screw for sideburner lid		2
L	Shoulder Screw		2
M	#10-24x1/2" Machine Screw		4
N	5mm Lock Washer		2
P	5mm Flat Washer		2

You may have spare hardware after assembly is complete. Après que l'Assemblée est terminée, vous devrez peut-être matériel de rechange. Pueden tener hardware de repuesto después de terminar de armarla.

HARDWARE LIST

Key	Description	Picture	Qty
Q	#10-24x3/8" Screw		2
R	#10-24 Flange Nut		2

You may have spare hardware after assembly is complete. Après que l'Assemblée est terminée, vous devrez peut-être matériel de rechange. Pueden tener hardware de repuesto después de terminar de armarla.